

Wall mount bracket



TECHNICAL DATA - MECHANICAL

- Made of aluminium
- Adjustable joint
- Internal cable management
- Load rating: 25kg (55lb)
- Length: 204mm (8in)
- The sealing rings OWBIP2 or OWBIP3 ensure an IP66 protection to the housing
- Unit weight: 0.6kg (1.3lb)

DESCRIPTION

Wall bracket with joint. It offers vandal proof protection, due to an internal cable channel.

For IP55 protection, make a hole in the supplied sheath of 2mm less of the cable diameter and combine with the existing hole of the bracket. The sealing rings OWBIP2 or OWBIP3 ensure a housing of IP66 protection.

TECHNICAL DRAWINGS

The indicated measurements are expressed in millimeters.

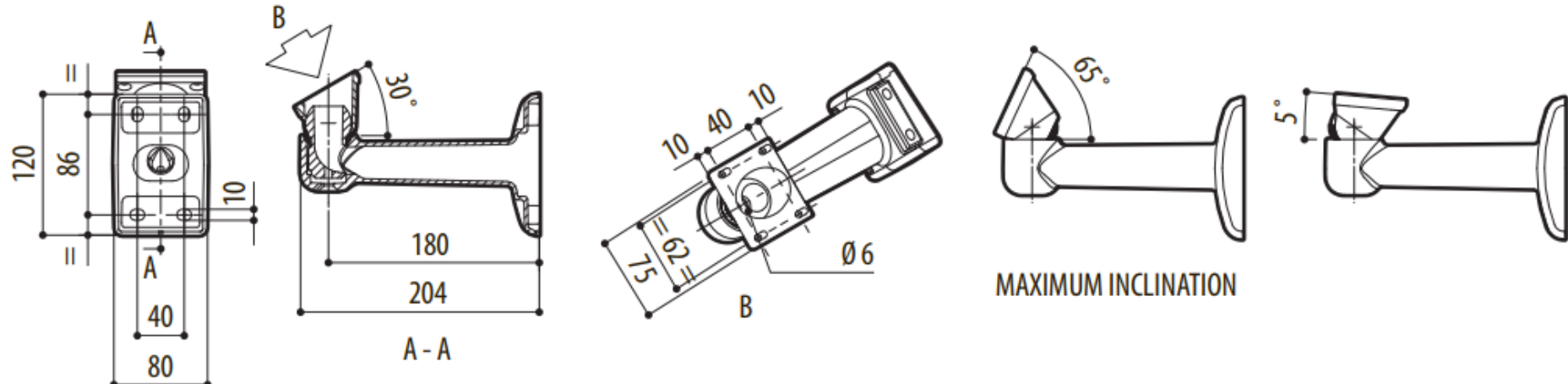

Pole mount adaptor



TECHNICAL DATA - MECHANICAL

- Made of aluminium
- Allows the internal cable management
- Load rating: 30kg (66lb)
- For pole diameters: from 65mm (2.6in) up to 140mm (5.5in)
- Unit weight: 0.9kg (2lb)

DESCRIPTION

Pole mount suitable for WBJA, WBMA, WBOVA2 and PTAC brackets. Allows the internal cable management.
Epoxy polyester powder painted.

TECHNICAL DRAWINGS

The indicated measurements are expressed in millimeters.

